

# Model M

## Multi-Jet Magnetic Water Meter



Water meters using the multi-jet principle are the best cost/performance, long life, flow measurement instruments. Wide clearances in the measuring chamber and negligible area of contact between static and moving parts are the main reasons for the high reliability of this design even in hard water. MH model for hot water available.



### Applications

For domestic, agriculture and industrial use

### Available Sizes

1/2" - 1 1/4" (15mm - 32mm)

### Standards

MID 2014/22/EC (based on OIML R49 EN 14154 and ISO 4064:2014), WRAS

### Features

- Only one moving part - the impeller - in contact with the water for minimum wear and utmost reliability
- Magnetically driven sealed registers. Stainless steel/glass encapsulated option is unconditionally guaranteed against fogging
- Wide selection of dial configurations (3 pointers; central pointer) and units of measurements
- Optional Electrical Output: EV, EF, Dialog 3G, ER

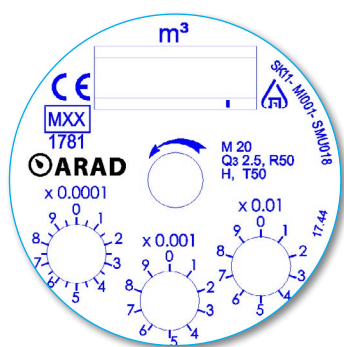

M type dial

### Technical Specifications

<b>Maximum Working Pressure</b>	10 bar
<b>Maximum Working Temperature</b>	50°C
<b>Meter body material</b>	Corrosion proof copper alloy
<b>Optional</b>	Highly reinforced composite material
<b>Coupling threads</b>	BSP, NPSM

# Model M

## Multi-Jet Magnetic Water Meter

### Dimensions

Model		M15 (short)	M15	M20	M25	M32
Nominal size	(mm)	15	15	20	25	30
	(inch)	1/2	5/8	3/4	1	1 1/4
L - Length without couplings (mm)		165	190	190	260	260
L <sub>1</sub> - Length with couplings (mm)		260	285	285	375	375
W- Width (mm)		95	95	95	105	105
H - Height (mm)		102	112	108	108	108
H - Height for 3G version (mm)		117	127	111	118	118
Weight (kg)		1.5	2	2	2.8	2.8
Weight with couplings (kg)		1.7	2.2	2.3	3.3	3.45
Weight (plastic body) (kg)		0.55	0.56	0.6	0.65	0.66

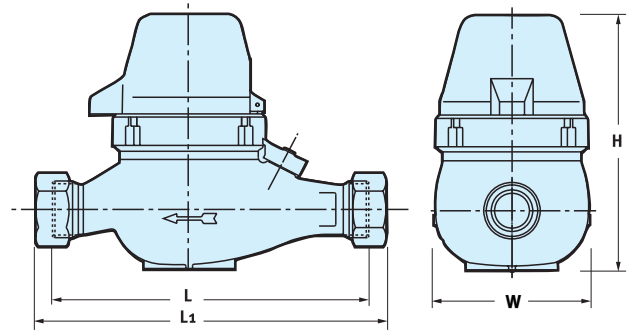

### Performance data:

Model	Nominal size (inch)	Q1 Minimum flowrate (m <sup>3</sup> /h)	Q2 Transitional flowrate (m <sup>3</sup> /h)	Q3 Nominal flowrate (m <sup>3</sup> /h)	Q4 Maximum flowrate (m <sup>3</sup> /h)	R Q3/ Q1	Indicating range (m <sup>3</sup> /h)	Smallest readable unit (liter)	Accuracy between Q4 & Q2	Accuracy between Q2 & Q1
M15	1/2	0.032	0.051	1.6	2	50	999,999	0.05	±2%	±5%
M20	3/4	0.050	0.080	2.5	3.125	50				
		0.063	0.102	4	5	63				
M25	1	0.080	0.128	4	5	50				
		0.079	0.126	6.3	7.875	80				
M32	1 1/4	0.126	0.202	6.3	7.875	50				
		0.100	0.160	10	12.5	100				

### Accuracy Curve

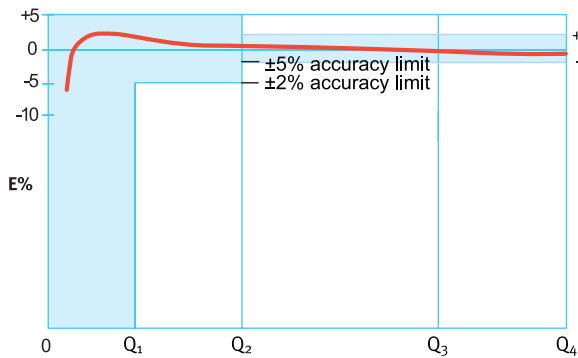

### Head Loss Curve

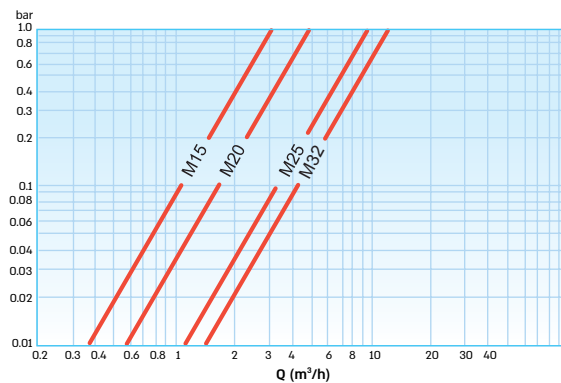

### Installation Requirements

- The Meter should be installed in horizontal position dial face up.
- Pipeline must be flushed before installation.
- The meter should be constantly full of water.